







## ORDERING FORM

**FIXTURE: PH09S PARKER BELLE STANDARD**

**EXAMPLE: PH09S-R280-100W-90-UNV-4K-MS-BLK-07**

CODE	WATTS & LUMENS	BEAM	VOLTAGE	KELVIN	OPTIONS	FINISH	ACCESSORIES
<b>PH09S-R280</b> Size 11"	<b>R280</b> 80W-11200L 100W-14000L 120W-16800L 150W-21000L	<b>60</b> <b>90</b> <b>110</b>	<b>UNV-</b> 100-277V  <b>480V-</b> Special Integral	<b>3K-</b> 3000K <b>4K-</b> 4000K <b>5K-</b> 5000K <b>6K-</b> 6000K	<b>DM-</b> Dimmable  <b>MS-</b> Motion Sensor	<b>WH - White</b> <b>BLK - Black</b>	<b>01-PH09-RDHK01</b> Round Hook <u><b>STANDARD</b></u>  <b>02-PH09-BUL02</b> Bulgin <u><b>STANDARD</b></u>  <b>03-PH09-YOKE03</b> Yoke Ceiling Mount  <b>04-PH09-CHS04</b> Chain Suspension Mount  <b>05-PH09-CARA05</b> Carabiner Suspension Mount  <b>06-PH09-DRVMOD06</b> Driver Module  <b>07-PH09-USHK07</b> US Hook Suspension Mount
<b>PH09S-R360</b> Size 14"	<b>R360</b> 100W-14000L 150W-21000L 200W-28000L						

ACCESSORIES						
						
01	02	03	04	05	06	07

# Parker Belle Standard PH09S



## Energy Efficient and Dimmable LED High Bay Fixture

The Parker Belle Standard PH09S is an LED high bay with efficiency at its core. It is designed to be placed between 19-26 ft. mounting heights for an optimal minimized glaring level. A unique feature is the disconnecting cable, which can quickly separate the driver from the LED module for easy maintenance. The unit comes with a round hook made of die-cast aluminum for a strong and easy installation. The PH09S is also dimmable from 0-10V and goes to 50% when no motion is detected. The attached cord is 6 feet long.

### FEATURES

- Low Glare
- IP65 / IK10
- SDCM 3 or 6
- Easy Cleaning
- Optional Beam Angle
- Dimmable, optional
- Excellent Heat Dissipation
- Two Finishes: Black and White
- 71,000 Hours (L70@Ta 25°C), 5 Year Warranty
- Replaces Traditional High Ceiling Applications

### APPLICATION

- **INDUSTRIAL**  
Warehouses, Production Halls, Parking Areas
- **EDUCATION**  
Classrooms, Cafeterias, Auditoriums, Sports Halls
- **SEMI-OUTDOOR**  
Car Garages, Pools, Airports, Train/Bus Stations, Gas Stations, Parks, Toll Stations
- **SHOP & RETAIL**  
Shopping Malls, Supermarkets, Retail Stores
- **ARCHITECTURAL**  
Exhibition Centers, Libraries, Museums, Concert Halls



### SPECIFICATIONS

Model No.	Power (W)	Lumens	lm/W
PH09S-R280	80	11200	140
PH09S-R280	100	14000	140
PH09S-R280	120	16800	140
PH09S-R280	150	21000	140
PH09S-R360	100	14000	140
PH09S-R360	150	21000	140
PH09S-R360	200	28000	140

**Notes:** Above lumens based on 4000K Ra: 80  
 All values in +25°C ambient temperature,  
 luminous flux tolerance +-5%  
 output power tolerance +-5%

### TECHNICAL PRODUCT INFORMATION

**Storage:** -40~+85°C    **Operating:** -20 ~+ 40° C  
**PF:** ≥0.93    **THD:** ≥20%    **Power Efficiency:** ≥0.90  
**Light Source:** SMD3030  
**Certification:** UL  
**Beam Angle:** 60°/ 90°/110°  
**CCT Range:** 3000K | 4000K | 5000K | 6000K  
**AC Input:** 100-277V; 480V is Integral 50/60Hz  
**Light Efficiency:** 140 lm/W  
**Waterproof:** IP65 & IK10  
**Recommended Installation Height:** 10 - 65ft  
**Optimal Minimized Glaring Level:** 19 - 26ft  
**Optional:** Motion Sensor, Dimmable  
**Function:** Dimming to be 0-10V

### ACCESSORIES



	IMAGE	PART #	DESIGNATION	MATERIAL	DESCRIPTION	QTY	ACCESSORY USE
<b>Standard</b>	01	PH09-RDHK01	Round Hook	Stainless Steel 304	2" x 1" x 1"	1 PC	Suspension
	02	PH09-BUL02	Bulgin	PC	120-277V	1 PC	Grade IP67
<b>Optional</b>	03	PH09-YOKE03	Yoke, R280	GALV Steel	9-3/4" x 1-5/8" x4"	1 PC	Ceiling Mount
	03	PH09-YOKE03	Yoke R360/ R380	GALV Steel	11-1/4" x 1-5/8" x4"	1 PC	Ceiling Mount
	04	PH09-CHS04	Chain	Stainless Steel	3'	1 PC	Suspension Mount
	05	PH09-CARA05	Carabiner	Stainless Steel	2" x1" x 1/4"	1 PC	Suspension Mount
	06	PH09-DRVMOD06	Driver Module		277-480V	1 PC	277-480V
	07	PH09-USHK07	US Hook	Stainless Steel	120-277V	1 PC	Suspension



## FEATURES



IP65



IK10



CLASS I



5 years  
warranty



RG0

Light-weight



Unique Heatsink



## SIZE

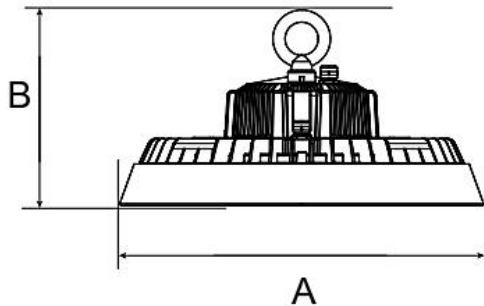

Model No.	Size A (inches)	Size B (inches)
PH09S-R280	11"	7"
PH09S-R360	14"	7 ½"



# INSTALLATION

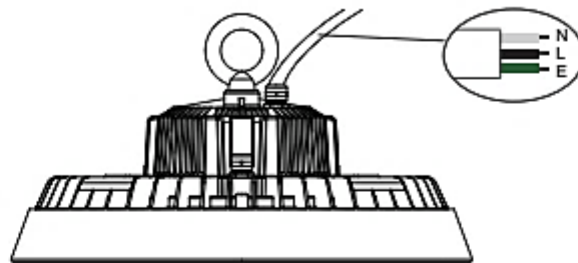

Note:  
"L" Black  
"N" White  
"E" Green

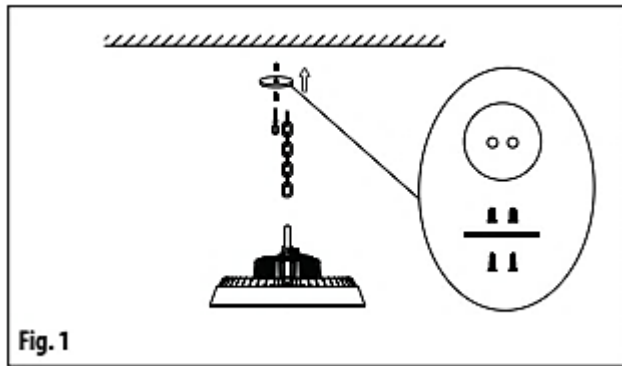

Fig. 1

## SUSPENSION MOUNT

- A. Mark correct position and screw hole.
- B. Mount hook and fixture.
- C. Connect the wire by junction box after the power has been turned off.
- D. Adjust the position of the fixture and clean it.

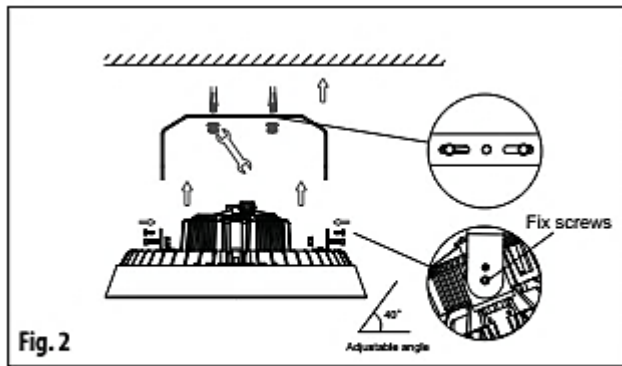

Fig. 2

## CEILING MOUNT

- A. Install the set screws.
- B. Put the lamp card into set screws and lock tightly.
- C. Connect the power cable.
- D. Adjust the lamp angle and clean it.